

SPECIFICATION OF AC CURRENT SENSOR

AC Current Sensor CTL Series

CTL Series are compact and CT(Current Transformer)type AC Current sensors for the purpose of measuring and controlling.

They are durable structure, molded with epoxy in plastic case.

Pass a cable through the center hole of the sensor, and you can measure AC Current in a high precision and a high reliability.

There are 2 series; CTL general purpose series for general measurement and CTL-Z series for precision measurement. It is therefore possible to select according to the requirement.

PRINCIPLE

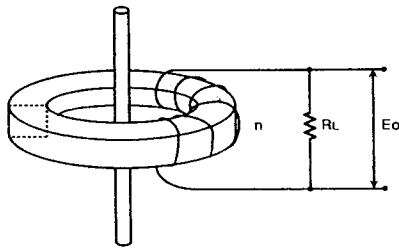

The basic principle is a Current Transformer with transforming ratio $1/n$. Flow the secondary current to load resistance, and you can transform it into Voltage signal.

$$E_o = K \cdot I_o \cdot R_L / n$$

- E_o : Output Voltage (Vrms)
- K : Coupling coefficient of CT.
- I_o : Primary Current (Arms)
- R_L : Load Resistance(Ω)
- n : Numbers of Secondary windings(Turns)

STRUCTURE

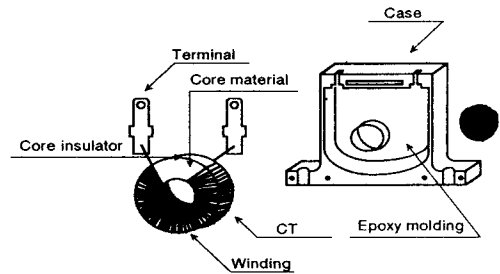

CT which is a ring core with toroidal windings is molded with epoxy in the plastic case, therefore a durable structure. The excellent isolation between CT and Thru-hole cable is assured. The secondary windings are output by lead wires or pins.

TYPICAL MODELS / SPECIFICATIONS TABLE

Models	Application	Dia. Thru-hole (mm) ± 0.5	Secondary Winding (Turns) ± 2	Non-distorted Output Voltage \leq Dist. 3%	Current Range (Arms)	Max. Allowable Current (Arms)	Outline Ref. (FIG)
CTL-6-L	General	6	800	1.0	0.1~40	60	5
CTL-6-S	Measurement	5.8	800	2.9	0.1~80	80	10
CTL-6-P		5.8	800	2.9	0.1~80	80	11
CTL-12-S36-10		12	1000	13.0	0.1~280	280	16
CTL-24-TE		24	1000	9.5	0.1~240	400	21
CTL-6-L-Z		6	800	0.65	0.001~15	60	5
CTL-6-S-Z	Precision Measurement	5.8	800	1.4	0.001~20	80	10
CTL-6-P-Z		5.8	800	1.4	0.001~20	80	11
CTL-12-S30-10Z		12	1000	4.0	0.001~100	280	16
CTL-12-S28-10Z		24	1000	3.7	0.001~80	400	21

N. B. There are other many standard products except the above models. Contact us please.

MODEL: CTL-6-L

CURRENT RANGE : 0.1...40 A

BANDWIDTH : 20.....50 KHz

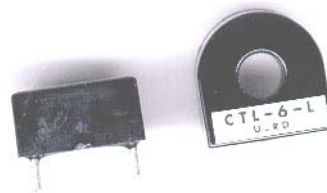

Output Waveform

$I_o = 5A$

$R_L = 1k\Omega$

Distortion: $\geq 10\%$

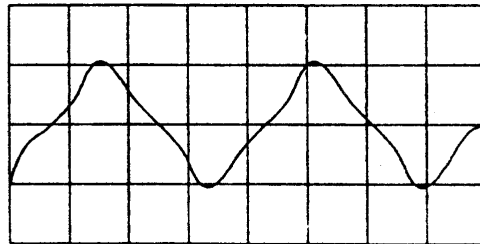

$I_o = 3A$

$R_L = 100\Omega$

Distortion: $\leq 1\%$

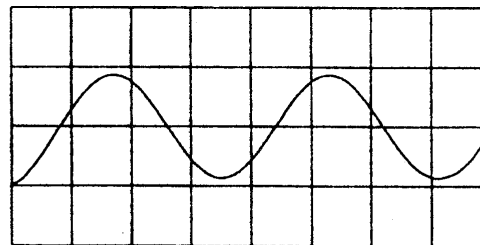

Output Voltage (E_o) vs Thru-hole Current (I_o) Characteristics

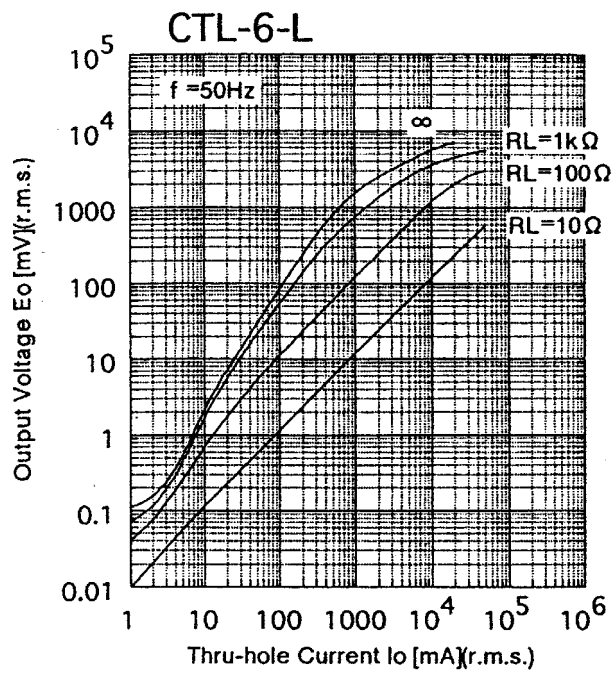

Coupling Coefficient (K) Characteristic

The output voltage (E_o) can be calculated by the following formula:

The coupling coefficient (K) is proportionally readable in the characteristic curves.

$$E_o = K \cdot I_o \cdot R_L / n \text{ (Vrms)}$$

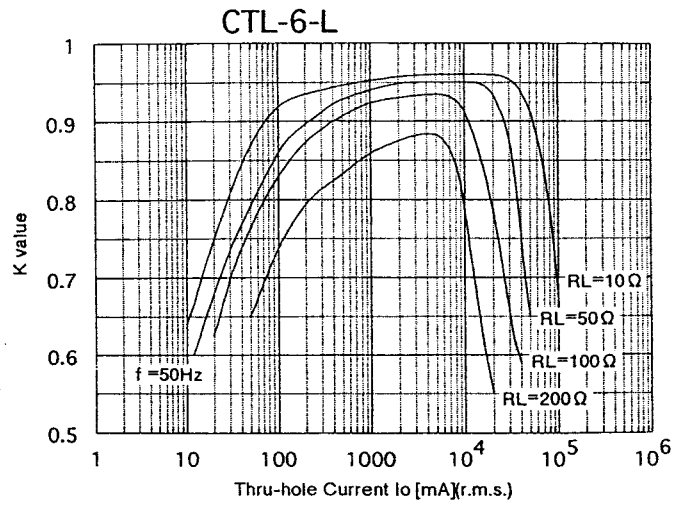

DIMENSION OF CTL-6-L

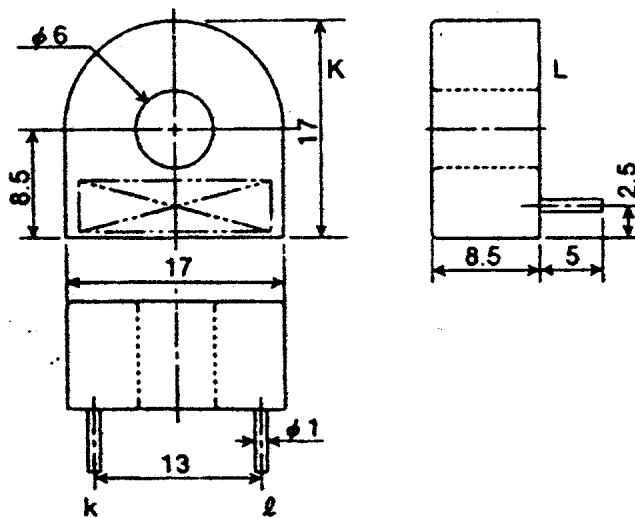

PRC Technologies Corporation Ltd.

T: 02 530 1619, 530-1714 F: 02 530 1731

Email: prctec@anet.net.th

www.prctechnologies.co.th